

## FyreWrap® MAX 2.0 Duct Insulation – Two-Layer ASTM E-2336 System

### Introduction

Unifrax's FyreWrap® MAX 2.0 Duct Insulation is a high-temperature insulation blanket specifically designed to provide a flexible enclosure for one- and two-hour rated commercial kitchen grease ducts. FyreWrap MAX 2.0 Duct Insulation provides a tested, fire-protective enclosure acceptable as an alternate to a traditional fire-rated shaft. Installed as a two-layer system, FyreWrap MAX 2.0 complies with ICC ES Acceptance Criteria for Grease Duct Enclosure Assemblies, AC101 (formerly ICBO) and ASTM E-2336. FyreWrap MAX 2.0 Duct Insulation offers the following product features:

- Complies with ASTM E-2336 and ICC ES criteria
- Two-layer system; inner layer utilizes butt joint
- High-temperature, biosoluble insulation
- Zero clearance to combustibles, at any location
- 2-hour fire endurance rating
- Alternate to shaft enclosure

### Product Components

Core Material: FyreWrap MAX 2.0 incorporates Insulfrax® Thermal Insulation as its core material. Insulfrax is a high-

### Typical Product Properties

ICC Evaluation Services (formerly ICBO) .....	Evaluation Service Report ESR-2224
Intertek Laboratories (OPL) Listed .....	File 16341-3, Design No. GD 524F, GD 529F, GD 564F, GD 600 F
ASTM E-2336 (AC101) .....	Complies
ASTM E-2336 (AC101) Internal Grease Duct Test .....	Zero Clearance to Combustibles at all locations on wrap
ASTM E-119 Full Scale Engulfment Test.....	2-hour Fire Resistance Rating
ASTM E-84/UL 723 Surface Burning Characteristics .....	UL File No. R14514
	<u>Unfaced Blanket</u> <u>Encapsulated</u>
Flame Spread/Smoke Developed Rating: .....	Zero/Zero                      <25/<50
ASTM E-814 Firestop Test .....	1- and 2-hour Fire Resistance Ratings
ASTM E-136 Non-Combustibility Test .....	Passes
ASTM C-518 Durability Test.....	Passes

Data are average results of tests conducted under standard procedures and are subject to variation. Results should not be used for specification purposes.

Complies with: NFPA 96 (all editions), 1997 ICBO Uniform Mechanical Code (UMC), 1997 ICBO Uniform Building Code (UBC), 2000, 2003 and 2006 International Mechanical Code (IMC), 2000, 2003 and 2006 IAPMO UMC (Uniform Mechanical Code).

California State Fire Marshal Listing      No: 2440-1478:100  
City of Los Angeles Approved:              RR 8459



FyreWrap® MAX 2.0 Duct Insulation

temperature insulation made from a calcia, magnesia, silica chemistry designed to enhance biosolubility. It provides excellent insulation in a noncombustible blanket product form.

Encapsulating Material: The core insulation blanket is completely encapsulated in an aluminum foil fiberglass reinforced scrim covering. This scrim provides additional handling strength as well as protection from moisture absorption and tearing.



Complies with:



## Typical Product Parameters

Thickness	2"
Density	8pcf
Standard Product Form	Scrim Encapsulated
Product Availability	24"w x 20LF 48"w x 20LF

## Installation

The FyreWrap MAX 2.0 Duct Insulation ICC ES System consists of a two-layer system applied directly to the duct surface. When desired, unfaced blanket is permitted for use as the inner layer. The outer layer requires encapsulated blanket. The FyreWrap MAX 2.0 insulation system may be installed at zero clearance to combustibles at any point.

The first layer can be installed with transverse (perimeter) joints butted and minimum 3" longitudinal overlaps on the topside of horizontal ducts. All overlaps for the second, or outer layer, are required to be a minimum of 3". For the second layer, transverse (perimeter) overlaps of adjacent blankets may be installed using one of the following three methods and as shown in Figure 1.

## Telescoping Overlap Wrap Technique:

This wrap technique is the most common method of installing FyreWrap MAX 2.0 where each adjacent blanket has one edge exposed and one edge covered by the next blanket.

Cut the first piece of inner layer insulation to a length sufficient to wrap around the duct and provide a 3" longitudinal overlap on the topside of the duct. Install the adjacent inner layer piece so that the blanket edge is butted against the preceding piece, forming a tight perimeter joint. This piece also requires a 3" longitudinal overlap on the topside of the duct. Space the starting edge of the outer layer a maximum 3" from the exposed edge of the inner layer. All joints on the second layer require a minimum 3" overlap. Ends of the outer overlaps occur on the topside of the horizontal section and backside of the vertical section of the duct, alternating nominal 8" on either side of the longitudinal centerline with each successive wrap piece. All cut edges shall be sealed with aluminum foil tape.

Figure 1. 2-layer detail

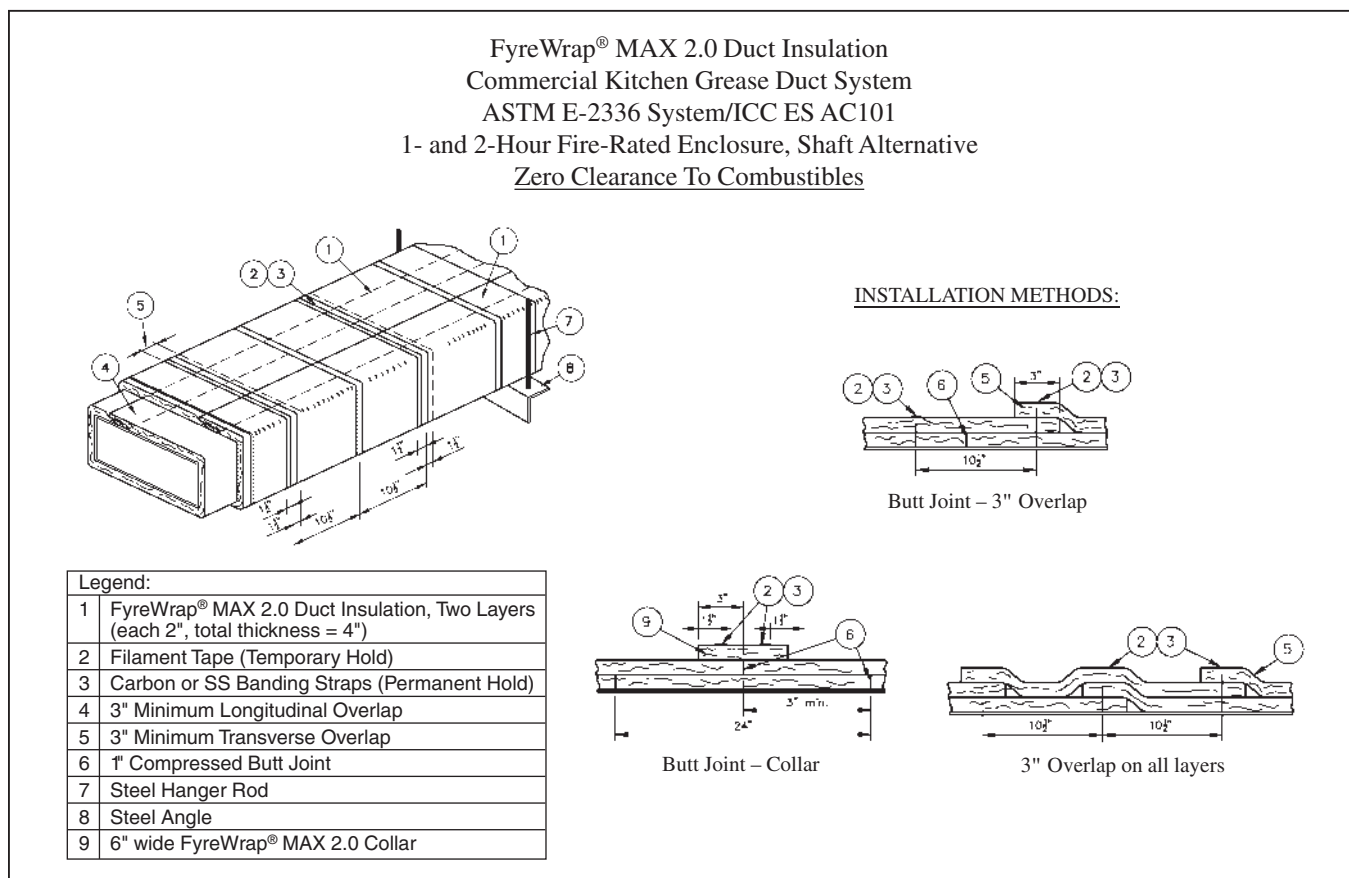

### Checkerboard Overlap Wrap Technique:

This installation uses a 3" overlap pattern with both edges of each alternating blanket covered by each adjacent blanket whose edges are exposed. The overlap joints in alternate layers of blanket resemble a checkerboard pattern in the completed installation. This technique is often utilized when a small section of duct wrap must be repaired.

### Butt Splice with Collar Wrap Technique:

This wrap technique permits installation with the blanket edges butted together and a 6" wide collar of blanket that is centered over the butt splice, overlapping each adjacent blanket 3". The collar can be field fabricated from FyreWrap MAX 2.0 rolls or purchased separately.

### Vertical Duct Runs

For vertical runs, the insulation can be applied to the duct in a continuous length applied parallel with the length of the duct as opposed to wrapping around the duct. All overlaps are to be maintained at a minimum 3" and are to occur a minimum of 6" from any corner of the duct. The second layer is to be centered over the overlapped seam of the first layer. Pins spaced a maximum 8" o.c. are to be placed at the centerline of all vertically oriented overlaps.

### Attachment Options

Three attachment options are available for installers. Choices are limited by the duct width dimension. Details on each option are provided below.

#### Banding Only: For Duct Widths 24" or Less

To temporarily secure the insulation, optional use of filament tape is permitted. Place carbon steel or stainless steel bands (min. ½" wide, nom. 0.015" thick) 1½" from each edge of each blanket overlap. Place additional bands in the field area between the overlaps on maximum 10½" centers. Tighten banding to firmly hold the wrap system in place but not so tight as to cut or damage the blanket. Pins are NOT required when this banding technique is used.

#### Banding and Pins: For Duct Widths Up To 48"

Weld 12-gauge steel insulation pins to the underside of horizontal runs and backside of vertical runs. Place pins at maximum 12" rows and on maximum 10½" centers. To temporarily secure the insulation, optional use of filament tape is permitted. Impale FyreWrap MAX 2.0 over the pins

and hold in place with minimum 2½" square or 1.5" round galvanized steel speed clips (washers). Turn down or cut off exposed ends of pins to eliminate safety hazards. Locate carbon steel or stainless steel bands (min. ½" wide, nom. 0.015" thick) 1½" from each edge of an overlap joint. Locate a second band midpoint between the overlapped joints, approximately 10½" on center. Tighten banding to firmly hold the wrap system in place but not so tight as to cut or damage the blanket. Cup head style pins are also permitted and shall be located at the same spacing as pre-welded pins.

#### Pins Only: For Any Duct Width

Weld 12-gauge steel insulation pins on all sides of the duct. Place insulation pins in rows (perpendicular to the length of the duct) spaced maximum 10½" on center. Pins in each row are maximum 5" from each duct edge and maximum 8" on center. Locate insulation overlaps so they are centered on the pins. Impale FyreWrap MAX 2.0 over the pins and hold in place with minimum 2½" square or 1½" round galvanized steel speed clips (washers) to keep the system from sagging. Turn down or cut off exposed ends of pins to eliminate safety hazards. Cup head style pins are also permitted and shall be located at the same spacing as pre-welded pins.

### Access Door

Field fabricated and prefabricated grease duct access doors are permitted for use with FyreWrap MAX 2.0 Duct Insulation. Installation details are provided below and in Figure 2.

Field fabricated access doors are protected with three layers of FyreWrap MAX 2.0 Duct Insulation. A gasket of 0.5" thick unfaced FyreWrap or ceramic fiber blanket is initially installed between the duct and the access door cover. Weld threaded rod to each corner of the access door opening. Cover with hollow steel tubes (optional) for easy removal of blanket. Weld at least four steel insulation pins to the outside of the door cover panel, 1" from each corner. Cut through the two layers of FyreWrap MAX 2.0 Duct Insulation already covering the duct and access door opening. Leave the interior piece in place. Cut back the outer layer to form an opening with perimeter dimensions that extend 1" beyond the inner layer. Cut a piece of FyreWrap MAX 2.0 that matches the dimensions of the opening and install over pins to fit tightly within the existing material. Cut an additional piece of insulation with perimeter dimensions that extend 1" beyond the layer below. Install over the insulation pins. Throughout the installation process, seal all cut edges with aluminum foil

### Attachment Options (Summary Chart):

Duct Dimension	Banding Only	Banding & Pins (Pins on Bottom)	Pins Only (All Four Sides)
Width ≤ 24"	●	●	●
Width Up To 48"		●	●
Width > 48"			●



tape. Secure with washers and bend over excess pin lengths to eliminate safety hazards. Place washers on threaded rod and secure with nuts. Do not install banding over this area. See Figure 2 for details.

Prefabricated – Ductmate Ultimate and Ductmate F2-HT prefabricated access doors are permitted and must be installed in accordance with Ductmate Industries, Inc. installation instructions and the applicable code. The prefabricated access door is protected with three layers of FyreWrap MAX 2.0. The first layer is cut to the size of the door. An successive layer (two additional layers) is sized to create an overlap of 1" beyond the layer immediately below. All edges of insulation blanket must be protected with aluminum foil tape. A No. 16 gauge outer plate the same dimension as the outer layer of insulation blanket is held in place over the insulation using threaded rod and wing nuts. The outer plate is supplied with the Ultimate door and F2-HT doors. Access doors are available from Ductmate Industries, Inc. Contact [www.ductmate.com](http://www.ductmate.com) or 1-800-245-3188 for additional information or local distributors. Ask for the Access Door Product Line Manager.

## Duct Support

Horizontal duct support systems do not require FyreWrap insulation when constructed using a minimum 0.5" diameter uninsulated all-thread steel rod and 2" x 2" x 0.25" uninsulated steel angle spaced a maximum 72" on center along the length of the duct. A minimum clearance of 1" is required between the protected duct and the steel rod. Vertical duct support systems do not require FyreWrap insulation when constructed using minimum 1½" x 1½" x ¼" steel angle brackets located on opposite sides of the duct, on the top and bottom of each floor-ceiling assembly. The supports are attached to the duct with welds. Maximum spacing between vertical supports shall be established by structural calculations in accordance with the applicable code, that are submitted to the building official for approval. See Figure 3 for details. For all other duct support configurations, a single layer of FyreWrap MAX 2.0 Duct Insulation is required on all components. Utilize a minimum 3" overlap (approximately one quarter turn) on all joints.

Figure 2. Access Door

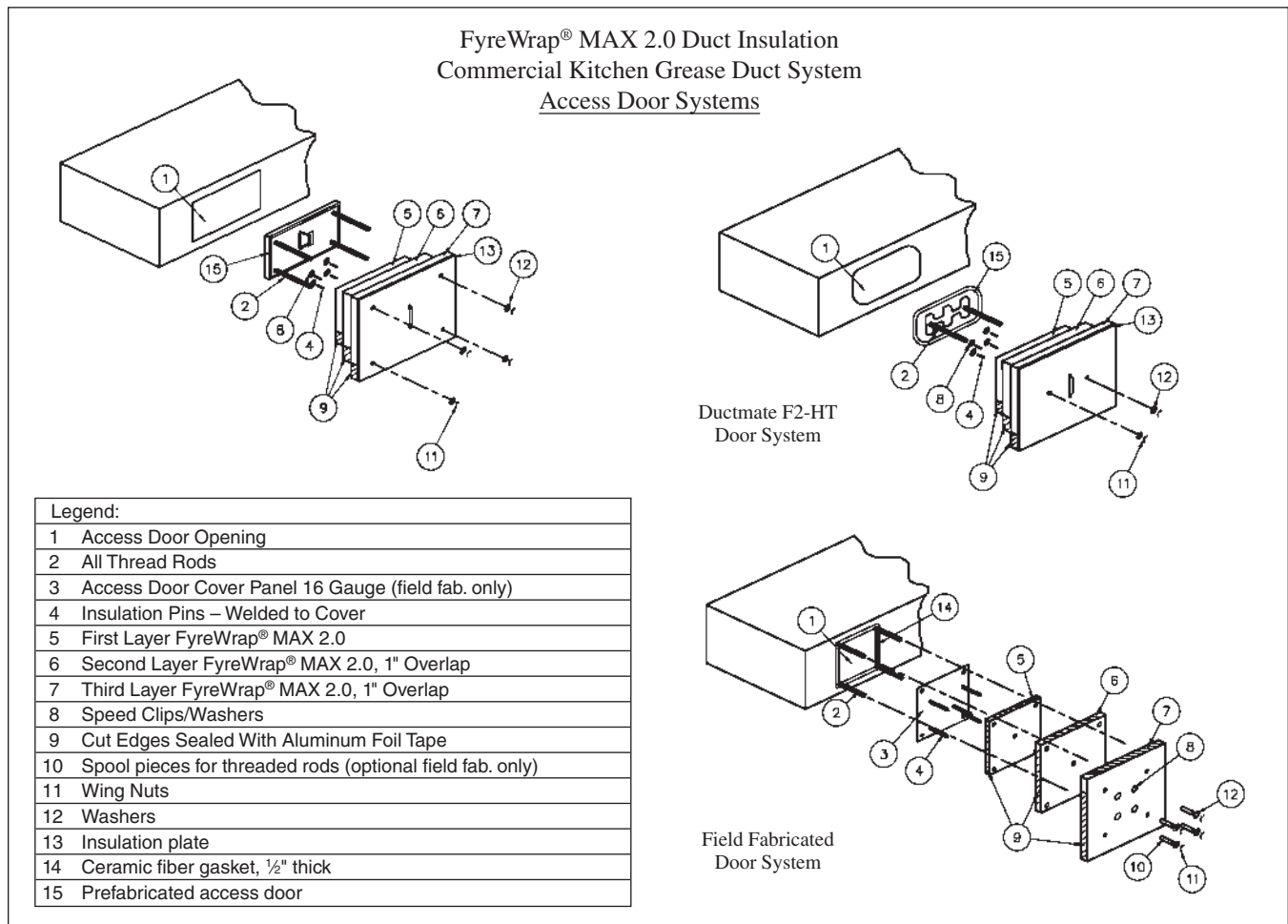

**Figure 3. Firestop Installation**

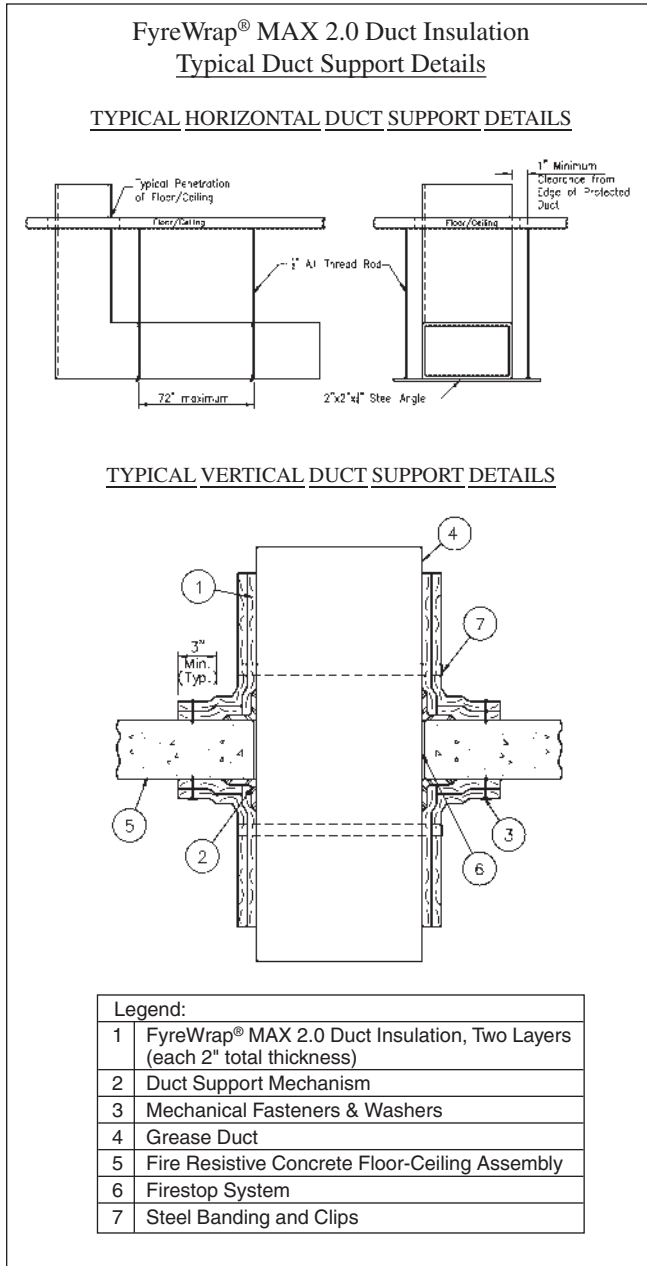

**Firestop Systems**

Where ducts insulated with FyreWrap MAX 2.0 pass through fire-rated walls and floors, the penetration opening shall be firestopped to maintain the fire rating of the assembly. Firestop Systems acceptable for use with FyreWrap MAX 2.0 ASTM E-2336 System at the time of printing are detailed below. Additional firestop systems may be developed and available for use. Contact Unifrax Application Engineering Group at 716-278-3888 for additional details and assistance or visit the test lab web site for the latest documentation.

**Figure 4. Firestop Installation**

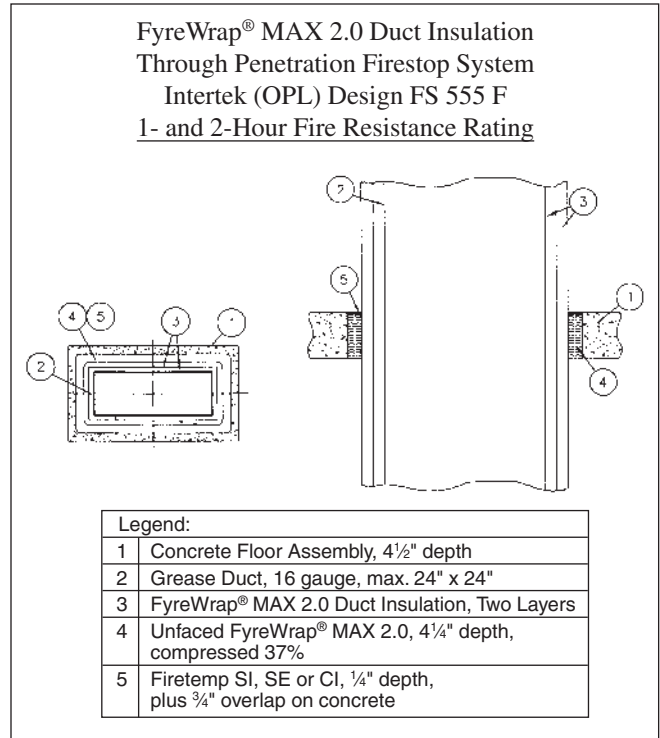

**Figure 5. Firestop Installation**

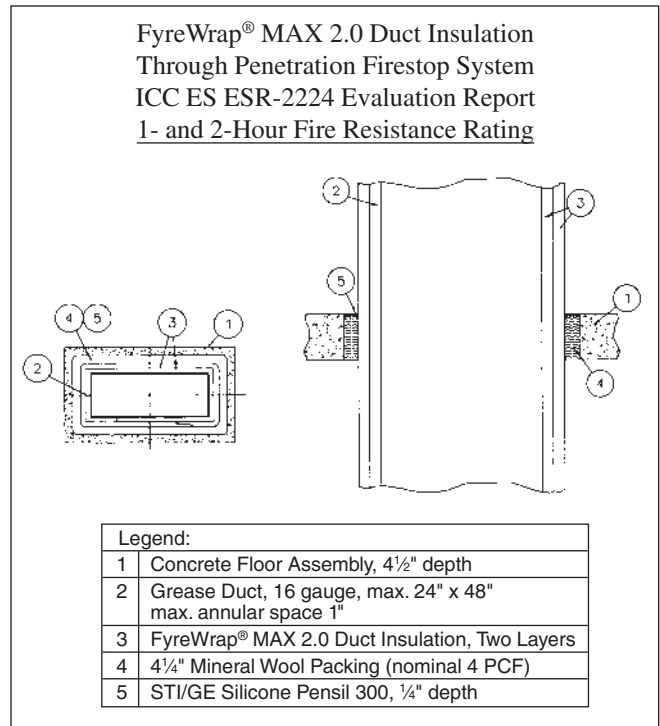

**Figure 6. Firestop Installation**

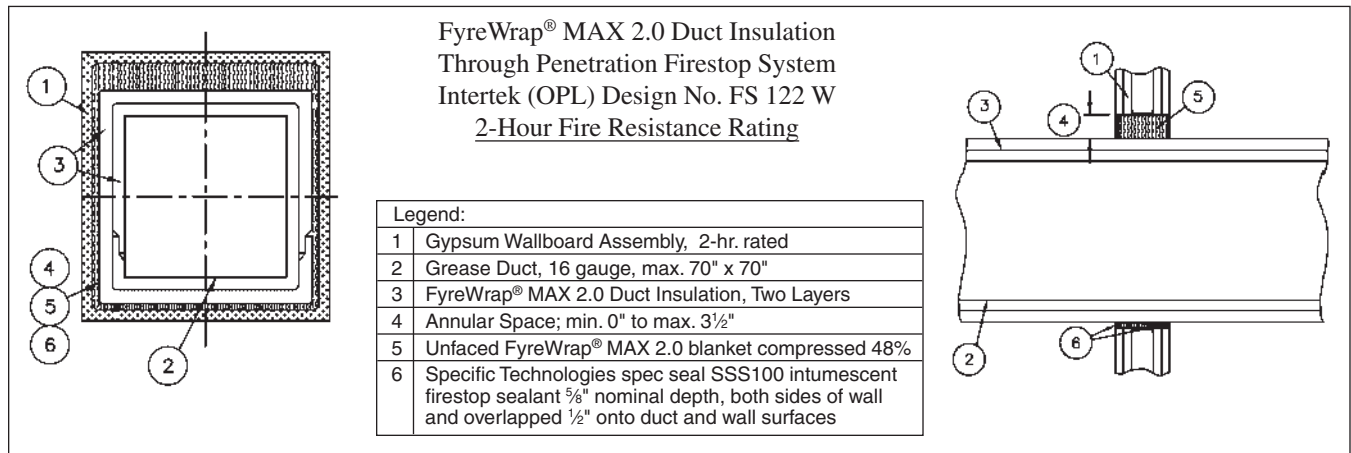

**Figure 7. Firestop Installation**

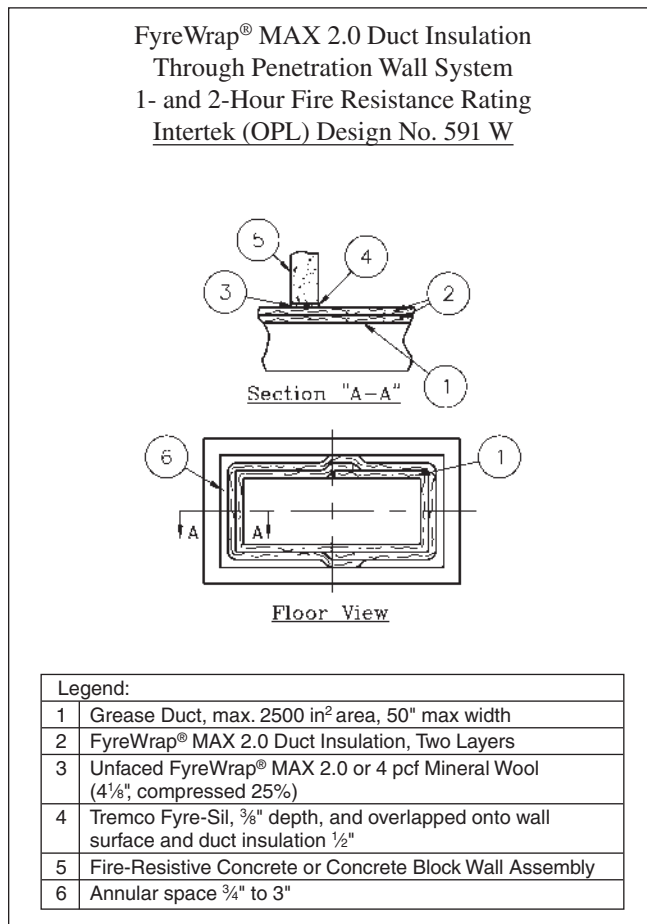

**Figure 8. Firestop Installation**

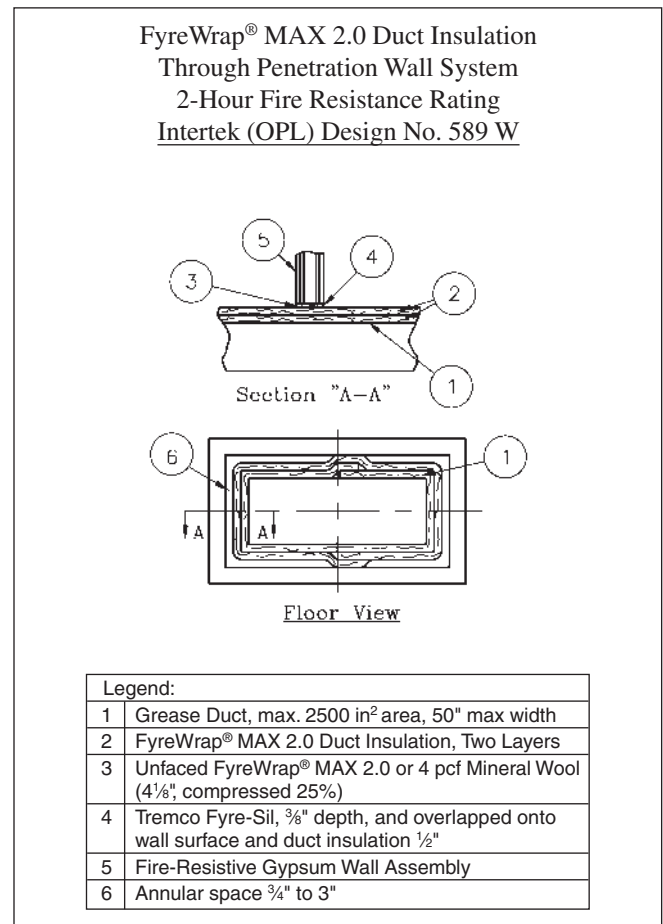

Refer to the product Material Safety Data Sheet (MSDS) for recommended work practices and other product safety information.



**Figure 9. Firestop Installation**

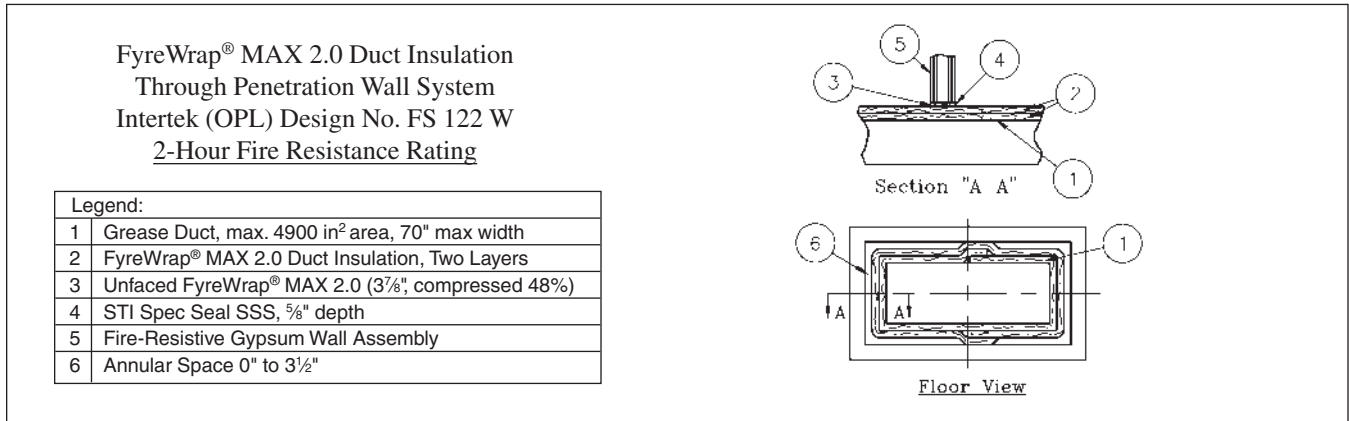

**Figure 10. Firestop Installation**

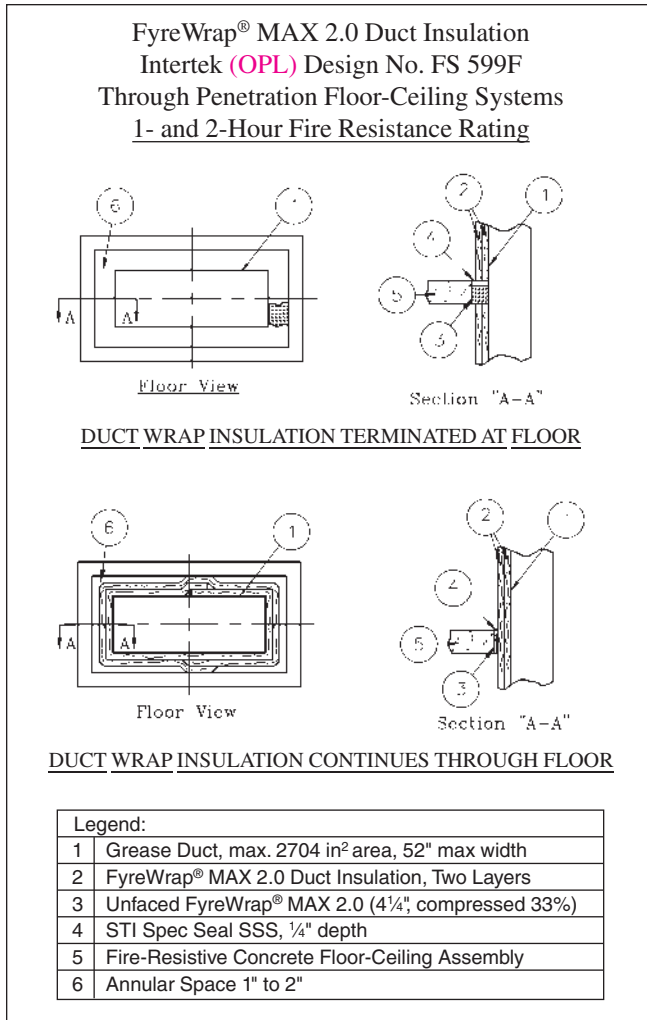

**Figure 11. Firestop Installation**

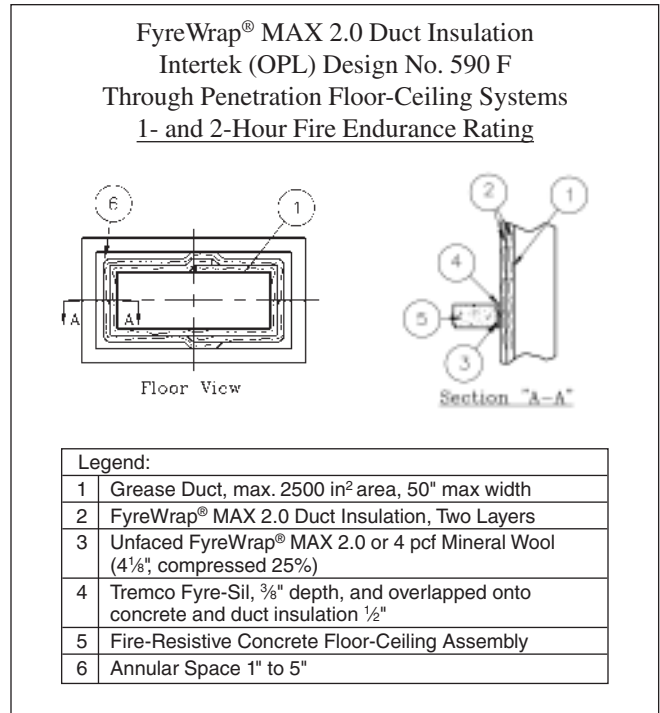

## Other Fire Protection Products and Applications

Unifrax offers many UL listed Fiberfrax® and FyreWrap® product forms and FyreWrap fire protection materials for passive fire protection applications, such as:

Product	UL File Number
FyreWrap® Duct Insulation	R14514
Insulfrax® 1800 Blanket	R14514
Fiberfrax® Durablanket® Ceramic Fiber Blanket	R14514
Fiberfrax® Duraboard® Ceramic Fiber Board LD	E75289
Fiberfrax® Ceramic Fiber Papers (110/440)	E75289
Fiberfrax® Ceramic Fiber Papers (970)	MH7030
Fiberfrax® Lo-Con™ Felt	MH7030
Fiberfrax® Moist Pak-D®	E75289

These products offer solutions in applications such as:

- Grease, HVAC Ducts
- Cable Trays, Conduits
- Control System Covers
- Above Ground Storage Tanks
- Marine Bulkheads, Decks
- Structural Steel
- Construction Joints
- Curtain Walls/Safing
- Circuit Protection
- Railroad Tank Cars
- Transit Cars
- Ships
- Expansion Joints
- Fire Door Seals
- Chimney Liners
- Ceiling Air Diffusers
- Hazardous Material Storage Containers



Unifrax has a wide range of FyreWrap fire protection materials available to provide passive fire protection solutions in a variety of applications in the commercial building, industrial facility and transportation industries.

For additional information about product performance or to identify the recommended product for your fire protection application, please contact the Unifrax Application Engineering Group at 716-278-3888.





OMEGA POINT  
LABORATORIES<sup>US</sup>

**INTERTEK TESTING SERVICES  
LISTED APPLIED FIRE PROTECTION**

**UNIFRAX I LLC**  
New Carlisle, IN

**FYREWAP MAX 2.0 DUCT  
INSULATION**

Nominal Density: 8 pcf

Tested Per:

ICC ES AC 101-04, Sect. 4.5 – Passed  
ICC ES AC 101-01, Sect. 5.4 – Passed  
ASTM E2336-04, Sect. 4.5 & 5.5 – Passed

W/N 14273  
ICC ESR-2224  
Reference  
Product Listing at  
[www.spec-direct.com](http://www.spec-direct.com)

The test data shown are average results of tests conducted under standard procedures and are subject to variation. Results should not be used for specification purposes.



Form C-1437  
Effective 10/07  
©2007, Unifrax I LLC  
All Rights Reserved  
Printed in USA  
Page 8 of 8

The following are registered trademarks of Unifrax: FyreWrap, Insulfrax, XFP, Lo-Con, Moist Pak-D, Fiberfrax, Durablanket, and Duraboard. The test data shown are average results of tests conducted under standard procedures and are subject to variation. Results should not be used for specification purposes.

Product Information Sheets are periodically updated by Unifrax. Before relying on any data or other information in this Product Information Sheet, you should confirm that it is still current and has not been superseded. A Product Information Sheet that has been superseded may contain incorrect, obsolete and/or irrelevant data and other information.

**Unifrax I LLC**  
Corporate Headquarters  
2351 Whirlpool Street  
Niagara Falls, New York 14305-2413  
Telephone: 716-278-3800  
Telefax: 716-278-3900  
Internet: [www.unifrax.com](http://www.unifrax.com)  
Email: [info@unifrax.com](mailto:info@unifrax.com)